



***Known for
Reliability
Since 1921***



product line

meat saws



**MODEL 11
MEAT SAW**
10" (255mm)



**MODEL 22SS
MEAT SAW**
12" (305mm)



**MODEL 22SS MEAT SAW
W/SS HEAD STRUCTURE**
12" (305mm)

	Model 11	Model 22SS	Model 22SS SS Head
Finish:	Powder Coating Nickel - Cast Aluminum	Stainless steel body Nickel	
		Cast Aluminum Head	SS Head & Door Structure
Motors:	1-1/2 HP (1.1kw), 1 or 3 phase, 50 or 60 Hz open high humidity		
Blade:	5/8" (16mm) x 78" (1981mm)-4 TPI	5/8 (16mm) x 91" (2311mm)-4 TPI	
Blade Speed:	3000 (914m)	3000 (914m)	
Cutting Clearance:	9-1/4" (235mm) H x 9-1/4" (235mm) W	11" (279.4mm) H x 11" (279.4mm) W	
Extra Cost Modifications:	Cord & plug, T.E. motors, watertight magnetic switches, 50 cycle 1 phase, front stationary stainless steel table.		

MODEL 1433 14" (355mm) MEAT SAW

Finish: Stainless steel, nickel.
 Head structure: Stainless steel, movable, ratchet tension
 Motor: 3 HP (2.2 kw), 50 or 60 Hz, 3 phase totally enclosed, 1 phase available.
 Switch: Watertight magnetic starter with thermal overload and under voltage protection.
 Blade & Speed: 5/8" (16mm) x 108" (2743mm), 3550 fpm (1082M) ,higher speed at no cost.
 Cutting Clearance: 14" (355.6mm) H x 13" (330mm) W.
 Meat Carriage: Stainless steel, EZ-Flow System 23-1/2" (597mm) L x 15-1/2" (394mm) W.
 Options: Stationary front table, optional motor voltages & phases, cord and plug.
 (Extra Cost)



MODEL 1433FH 14" (355mm) MEAT SAW

Finish: Stainless steel, nickel.
 Head structure: Fixed, stainless steel.
 Motor: 3 HP (2.2kw), 50 or 60 Hz, 3 phase totally enclosed, 1 phase available.
 Switch: Watertight magnetic starter with thermal overload and under voltage protection.
 Blade & Speed: 5/8" (16mm) x 108" (2743mm), 3550 fpm (1082m), higher speed at no cost.
 Cutting Clearance: 13-3/8" (339.7mm) H x 13" (330mm) W.
 Meat Carriage: Stainless steel, EZ-Flow System 23-1/2" (597mm) L x 15-1/2" (394mm) W.
 Options: Stationary front table, optional motor voltages and phases, cord and plug.
 (Extra Cost)

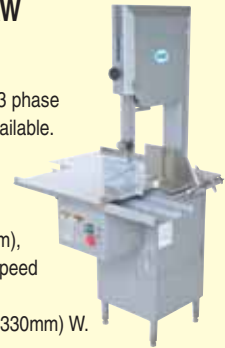

MODEL 3334SS-4003 16" (405mm) MEAT SAW

Finish: Stainless steel, nickel.
 Head Structure: Cast aluminum, movable, ratchet tension.
 Motor: 3 HP (2.2kw), 50 or 60 Hz, 3 phase totally enclosed, 1 phase available.
 Switch: Watertight magnetic starter with thermal overload and under voltage protection.
 Blade & Speed: 5/8" (16mm) x 124" (3150mm), 4000 fpm (1219m), higher speed at no cost.
 Cutting Clearance: 13-1/4" (336.5mm) H x 15-1/2" (393.7mm) W.
 Meat Carriage: Stainless steel, EZ-Flow System 25-9/16" (649.3mm) L x 18" (457mm) W.
 Extra Cost Modifications: Stainless steel head, cord and plug, water jet blade cleaning system.



MODEL 3334SS-4003FH 16" (405mm) MEAT SAW

Finish: Stainless steel, nickel.
 Head Structure: Fixed, stainless steel.
 Motor: 3 HP (2.2kw), 50 or 60 Hz, 3 phase totally enclosed, 1 phase available.
 Switch: Watertight magnetic starter with thermal overload and under voltage protection.
 Blade & Speed: 5/8" (16mm) x 124" (3150mm), 4000 fpm (1219m), higher speed at no cost.
 Cutting Clearance: 13-1/8" (333.4mm) H x 15-1/2" (393.7mm) W.
 Meat Carriage: Stainless steel, EZ-Flow System 25-9/16" (649.3mm) L x 18" (457mm) W.
 Extra Cost Modifications: Cord and plug, water jet blade cleaning system.

MODEL 3334SS 16" (405mm) MEAT SAW "ORIGINAL STANDARD"

Finish: Stainless steel, nickel.
 Head Structure: Cast aluminum, movable, ratchet tension.
 Motor: 2 HP (1.5kw), 50 or 60 Hz, 1 or 3 phase open.
 Switch: General purpose, thermal overload.
 Blade & Speed: 5/8" (16mm) x 124" (3150mm), 3200 fpm (975m).
 Cutting Clearance: 13-1/2" (342.9mm) H x 15-1/2" (393.7mm) W.
 Meat Carriage: Stainless steel.
 15-1/2" (393.7mm) x 23-1/2" (597mm).
 Options: Stainless steel head, watertight switch, stationary front table, cord and plug.
 (Extra Cost)



MODEL 3334SS 16" (405mm) TRIM CUTTER MEAT SAW

True left hand feed shown, right hand feed available.
 Stationary front table.
 Less meat gauge plate assembly.
 Stainless steel head and door structure.
 3 HP (2.2kw), 50 or 60 Hz.
 1 or 3 phase.

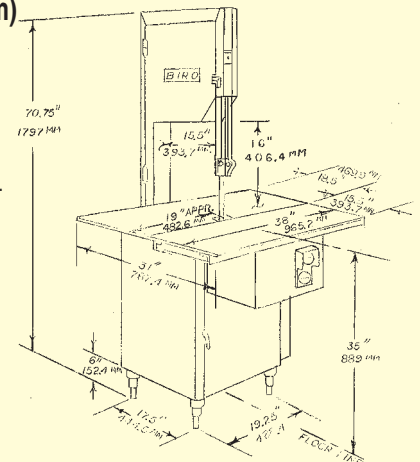

Call factory for other designs.

meat saws

MODEL 44SSFH 18" (455mm) MEAT SAW

Finish: Stainless steel, nickel.
 Head Structure: Fixed, stainless steel.
 Motor: 3 HP (2.2kw), 50 or 60 Hz, 3 phase open.
 Switch: Watertight magnetic starter with thermal overload and under voltage protection.
 Blade & Speed: 5/8" (16mm) x 142" (3606.5mm) long, 4000 fpm (1219m), higher speed at no cost.
 Cutting Clearance: 17-1/8" (333.4mm) H x 17-5/32" (435.8mm) W.
 Meat Carriage: Stainless steel, EZ Flow System 25-9/16" (646mm) L x 18" (457mm) W.
 Options: Various table designs, 5 HP (3kw) motor and voltages, left hand feed, cord and plug, numerous other options (contact factory for more information).



MODEL 44SSFH 18" (455mm) MEAT SAW

Optional front stationary heavy duty table. Optional inside and outside roller conveyor tops also available.

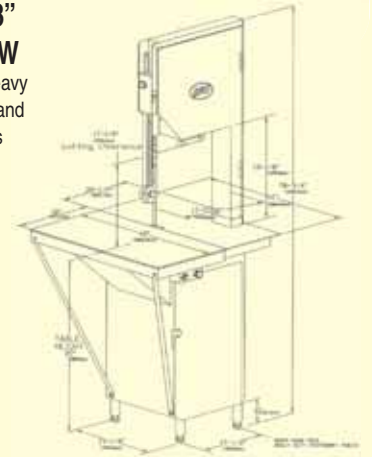

MODEL 55 22" (558mm) MEAT SAW

Finish: Stainless steel, nickel.
 Head Structure: Fixed, stainless steel.
 Motor: 5 HP (3kw), 50 or 60 Hz, 3 phase totally enclosed.
 Switch: Watertight magnetic starter with thermal overload and under voltage protection.
 Blade & Speed: 3/4" (19mm) x 164-1/2" (4178.3mm), 3880 fpm (1180m), higher speed at no cost.
 Cutting Clearance: 18" (457.2mm) H x 21" (533mm) W.
 Meat Carriage: Stainless Steel, EZ-Flow System 28-3/8" (720mm) L x 19-3/8" (492mm) W.
 Options: Various table designs, optional motors and voltages, left hand feed, cord & plug, numerous other options (contact factory for more information).



MODEL 55 22" (558mm) MEAT SAW

Optional heavy duty two way inside and outside roller conveyor tops (32 rollers) 36" (419mm)L x 40" (1016mm)W. See standard Model 55 specifications at left. Optional front stationary table is also available.

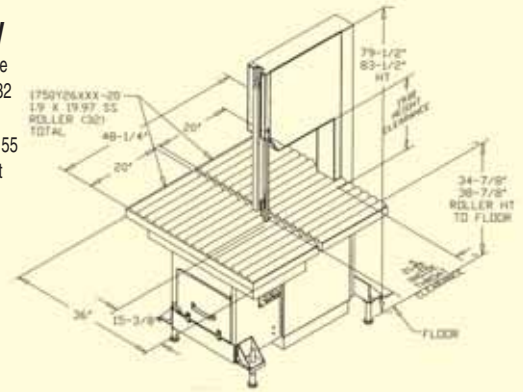

MODEL 4436 DESIGN 5 BREAKING SAW

Finish: Base & head structure stainless steel.
 Motor: 5 HP (3kw), 50 or 60 Hz, 3 phase.
 Switch: Watertight magnetic remote with push button start stop station.
 Blade & Speed: 164-1/2" (4178.3mm) x 1" (25.4mm) x .035" (0.88mm) @ 4000 fpm (1219m).
 Cutting Clearance: 17-1/4" (435mm)
 Cutting Width: 31" (787mm) throat.
 Tables: Right hand feed.
 Standard Equipment: Stationary front table 34-1/8" (867mm) x 20" (508mm), stationary rear table 34-1/8" (867mm) x 30" (762mm).
 Options: Outriggers, 5/8" (16mm) x .022" (0.56mm) wheels, left hand operation, 7-1/2 HP (5.6kw).



MODEL 4436 DESIGN 11 BREAKING SAW

Finish: Base & head structure stainless steel.
 Motor: 5 HP (3kw), 50 or 60 Hz, 3 phase.
 Switch: Watertight magnetic remote with push button start stop station.
 Blade & Speed: 164-1/2" (4178.3mm) x 1" (25.4mm) x .035" (0.88mm) @ 4000 fpm (1219m).
 Cutting Clearance: 13-1/8" (333mm)
 Cutting Width: 31" (787mm) throat.
 Meat Carriage: Right hand feed, heavy duty, inside & outside lift-up moving tables 48" (1219mm) x 40" (1016mm).
 Options: Outriggers, 5/8" (16mm) x .022" (0.56mm) wheels, left hand operation, 7-1/2 HP (5.6kw).



MODEL 4436 DESIGN 5E-3 BREAKING SAW

Finish: Base & head structure stainless steel.
 Motor: 5HP (3kw), 50 or 60 Hz, 3 phase.
 Switch: Watertight magnetic remote with push button start stop station.
 Blade & Speed: 164-1/2" (4166mm) x 1" (25.4mm) x .035" (0.88mm) @ 4000 fpm (1319m).
 Cutting Clearance: 15" (381mm).
 Cutting Width: 31" (787mm) throat.
 Standard Equipment: Right hand feed, two way roller conveyor tops 54" (1348mm) x 48" (1219mm), stabilizing support system.
 Options: 5/8" (16mm) x .022" (0.56mm) wheels, left hand operation, various roller configurations, 7-1/2 HP (5.6kw).



MODEL 4436 DESIGN 13B BREAKING SAW

Finish: Base & head structure stainless steel.
 Motor: 5 HP (3kw), 50 or 60 Hz, 3 phase.
 Switch: Watertight magnetic remote push button start stop station.
 Blade & Speed: 178-1/2" (4534mm) x 1" (25.4mm) x .035" (0.88mm) @ 4000 fpm (1219m).
 Cutting Clearance: 19-3/4" (502mm).
 Cutting Width: 31" (787mm) throat.
 Meat Carriage: Right hand feed, heavy duty, inside & outside moving tables 48" (1219mm) x 40" (1016mm).
 Standard Equipment: Stabilizing support system.
 Options: 5/8" (16mm) x .022" (0.56mm) wheels, left hand operation, 7-1/2 HP (5.6kw).



Call factory for other designs.

auto feed mixer grinders

MODEL MINI-22 MIXER GRINDER

Finish: Stainless steel hopper, frame, lid, enclosure, paddle, bowl, ring, and auger.

Motors: Auger-2 HP (1.5kw), 208V, 50 Hz or 60 Hz, 1 or 3 phase.
Mixer-1 HP (.75kw), 208, 50 Hz or 60 Hz, 1 or 3 phase..

Drive System: Double-reduction, direct-drive gearmotor (both auger and mixer)

Bowl Type: Size 22, uses size 22 plate and knives.

Hopper Capacity: Up to 45 lbs. (20kg).

Output Capacity: Up to 22 lbs. (10kg) per minute (1/8" (3.5mm) plate).

Standard Equipment: Spurt guard, grinder stand w/locking swivel casters, 10' cord and plug, safety interlock on lid.

Options: Pneumatic footswitch, stainless steel casters, size 22 knives and plate.
(Extra Cost)



MODEL MINI-32 MIXER GRINDER

Finish: Stainless steel hopper, frame, lid, and paddle. Tinned bowl, ring, and auger.

Motors: Auger-3 HP (2.2kw), 208V, 60 Hz, 3 phase. 50 Hz available; 60Hz, 1 Phase.

Drive System: Auger-single reduction chain drive, Mixer-double reduction gear drive.

Bowl Type: Size 32, uses size 32 plate and knives.

Hopper Capacity: Up to 65 lbs. (30kg).

Output Capacity: Up to 60 lbs. (27kg)/minute.

Standard Equipment: Splash shield, ring wrench, 10' cord and plug, stainless steel grinder stand with 5" DIA. total-lock swivel casters with preventz additive. Safety interlock on lid and tub.

Options: Size 32 plate and knife, pneumatic or electric footswitch 3 HP (2.2kw). Single (1) phase operation, 5" locking swivel casters, stainless steel casters.
(Extra Cost)



MODEL AFMG-24 MIXER GRINDER

Finish: Stainless steel hopper, frame, legs, lid, and paddle. Tinned bowl, ring, and auger.

Motors: Standard: 5 HP (3.7kw), 208V, 60 Hz, 3 phase
Optional: 7-1/2 HP (5.6kw), 208V, 60 Hz, 3 phase
(Extra Cost) 7-1/2 HP (5.6kw), 220/380V, 50 Hz, 3 phase
5 HP (3.7kw), 220V, 50 Hz, 3 phase
5 HP (3.7kw), 220V, 60 Hz, 1 phase.

Drive System: Tandem single reduction oil bath speed reducers with heavy duty mechanical clutch.

Bowl Type: Size 32, uses size 32 plate and knives.

Hopper Capacity: Up to 145 lbs. (66kg).

Output Capacity: Up to 68 lbs. (31kg)/minute.

Standard Equipment: Splash shield, ring wrench, 8' (2.4m) cord and plug on 3 phase only.

Options: Size 32 plate and knife, stainless steel bowl, ring, and auger, adjustable legs and casters, pneumatic or electric footswitch, meat lug holder, right or left feed inlet.
(Extra Cost)



Shown with optional extra cost casters.

MODEL EMG-32 ERGONOMIC MIXER GRINDER

Finish: Stainless steel hopper, frame, legs, lid, and auger. Tinned bowl, ring, and auger.

Motors: Auger-7-1/2 HP (5.6kw), 208V, 60 Hz, 3 phase
Mixer-3/4 HP (.56kw), 208V, 60 Hz, 3 phase
(Other voltages call factory). 50 Hz available.

Drive System: Auger-single reduction chain drive
Mixer-double reduction chain drive.

Bowl Type: Size 32, uses size 32 plate and knives.

Hopper Capacity: Up to 150 lbs. (68kg).

Output Capacity: Up to 80 lbs. (36.3kg)/minute first grind.
Up to 56 lbs. (25.4kg)/minute second grind.

Standard Equipment: Stainless steel auger and paddles (2), splash shield, ring wrench, pneumatic footswitch, 11' cord and plug, reversible paddles, meat cart less lugs, locking swivel casters with preventz additive.

Options: Size 32 plate and knife, electric footswitch.
(Extra Cost)



MODEL AFMG-48II MIXER GRINDER

Finish: Stainless steel hopper, frame, legs, lid and paddle. Tinned bowl, ring, and auger.

Motors: Auger-7-1/2 HP (5.6kw), 208V, 60 Hz, 3 phase
Mixer-1-3/4 HP (1.3kw), 208V, 60 Hz, 3 phase
(Other voltages call factory). 50 Hz available.

Drive System: Auger-single reduction chain drive
Mixer-Direct Drive.

Bowl Type: Size 48, uses size 32 plate and knives.

Hopper Capacity: Up to 200 lbs. (91kg).

Output Capacity: Up to 65 lbs. (30kg)/minute.

Standard Equipment: Splash shield, ring wrench, 12' cord and plug for U.S. 220V, locking swivel casters with preventz additive, no inlet hopper.

Options: Right side inlet.
(No Cost)
Options: 10 HP (7.5kw) auger motor, electric or pneumatic footswitch, stainless steel ring, auger, and bowl, size 32 plate and knife.
(Extra Cost)
Accessory cleaning and storage rack, extra long stainless steel legs, connecting horn and seal for tandem operations. Left side inlet hopper.



MODEL AFMG-52 MIXER GRINDER

Finish: Stainless steel hopper, frame, lid and paddle. Tinned bowl, ring, and auger.

Motors: Auger-7-1/2 HP (5.6kw), 208V, 60 Hz, 3 phase
Mixer-1-3/4 HP (1.3kw), 208V, 60 Hz, 3 phase
(Other voltages call factory). 50 Hz available.

Switch: Watertight magnetic switch system with thermal overload protection. Magnetic safety interlocks on hopper lid.

Drive System: Auger-single reduction chain drive.
Mixer-Direct Drive.

Bowl Type: Size 52, uses size 52 plate and knives.

Hopper Capacity: Up to 200 lbs. (91kg).

Output Capacity: Up to 100 lbs. (45.5kg)/minute.

Standard Equipment: Splash shield, ring wrench, 12' cord and plug for U.S. 220V, locking swivel casters with preventz additive, no inlet hopper.

Options: Right side inlet.
(No Cost)
Options: 10 HP (7.5kw) auger motor, electric or pneumatic footswitch, stainless steel ring, auger, and bowl, size 52 plate and knife. Accessory cleaning and storage rack, extra long stainless steel legs, connecting horn and seal for tandem operations.
(Extra Cost)



auto feed mixer grinders

MODEL AFMG-52-4 MIXER GRINDER

Finish: Stainless steel hopper, frame, legs, lid and paddle. Tinned bowl, ring, and auger.
Motors: Auger 10 HP (7.5kw) totally enclosed motor. Mixer 5HP (3.7kw) totally enclosed motor. (Other voltages call factory). 50 Hz available.
Switch: Watertight magnetic switch system with thermal overload protection. Magnetic safety interlocks on hopper lid, includes 12' 6-4 power cord.
Drive System: Auger-single reduction (35 pitch - 4 row) roller drive chain with tapered roller bearings; Mixer-double reduction gear box and open face gear drive
Bowl Type: Size 52, uses size 52 plate and knives.
Hopper Capacity: Up to 400 lbs. (182kg)
Output Capacity: Up to 100 lbs. (45.5kg)/minute.
Standard Equipment: 35 degree right hand inlet, stainless steel 2nd grind paddle with center arm, adjustable legs with casters, splash shield, and ring wrench, 12' 6-4 cord.
Options: Stainless steel bowl, ring and auger, size 52 plate and knife, bolt on hinged step, electric or pneumatic footswitch, connecting horn and seal for tandem operations 550 volt.



MODEL AFMG-56-4 MIXER GRINDER

Finish: Stainless steel hopper, legs, frame, bowl, ring, auger, and paddles.
Motors: Auger-15 HP (11.2kw), 208V, 60 Hz, 3 phase. Mixer-5 HP (3.7kw), 208V, 60 Hz, 3 phase. (Other voltages call factory). 50 Hz available.
Drive System: Auger-single reduction synchronous drive belt. Mixer-double reduction synchronous drive belt.
Bowl Type: Size 56, uses size 56 plate and knives.
Hopper Capacity: Up to 400 lbs. (182kg)
Output Capacity: Up to 200 lbs. (91kg)/minute.
Standard Equipment: Splash shield, ring wrench, 9' cord no plug.
Options: Wire grate style lid, right side inlet feed tube, size 56 plate and knife. Locking swivel casters, footswitch available (electric or pneumatic).



MODEL AFMG-56 MK III MIXER GRINDER

Finish: Stainless steel hopper, legs, frame, bowl, ring, auger, and paddles.
Motors: Auger-20 HP (14.9kw), 208V, 60 Hz, 3 phase. Mixer-5 HP (3.7kw), 208V, 60 Hz, 3 phase. (Other voltages call factory). 50 Hz available.
Drive System: Auger-single reduction chain drive. Mixer-double reduction chain drive.
Bowl Type: Size 56, uses size 56 plate and knives.
Hopper Capacity: Up to 800 lbs. (362.9kg)
Output Capacity: Up to 250 lbs. (113.7kg)/minute.
Standard Equipment: Splash shield, ring wrench, pneumatic lid lift. 9' cord no plug.
Options: Wire grate style lid, right side inlet feed tube, size 56 plate and knife, locking swivel casters.



TANDEM SYSTEMS

Model AFMG-56 MK III to AFMG-56 MK III Tandem System (Right to Left)

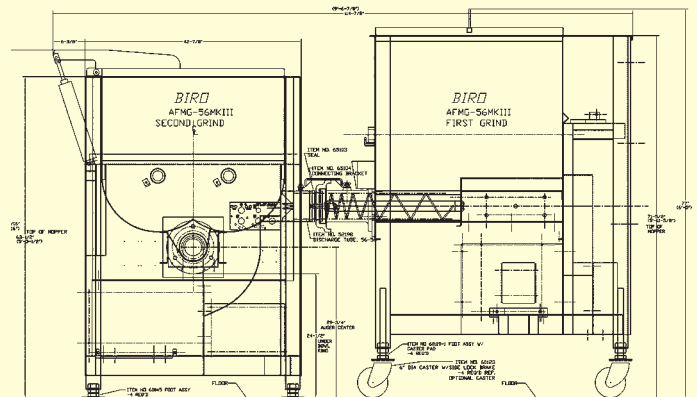

(Call factory for various configurations)

tenderizers

MODEL PRO-9 SERIES TENDERIZERS

Finish: Stainless steel case and top. Lexan Hopper Cover
Motors: 1/2 (.38kw) or 3/4 (.56kw) HP, 115-60-1 or 230-60-1 open type. 50 Hz available.
Switch: On/Off toggle type with cover safety switch.
Transmission: Oil bath gear box with Polyflex double-V belt.
Cutting groups: Stainless steel with stainless steel spacers and combs.
No Cost Options: 140 RPM roller speed (HD units only, upon request).
Standard Equipment: Tenderizing / knitting assembly 5' cord and 3 prong molded grounded plug, 115 volt.
Options: Cutlet cradle, scoring rollers, star rollers, stir fry/stew cutter assemblies in the following widths: 1/4" (6.3mm) (HD only), 3/8" (9mm) (HD only), 9/16" (14mm) (HD only), 3/4" (19mm), 7/8" (22mm), 1" (25mm), 1-1/4" (32mm), 1-9/16" (40mm), 2" (51mm), stainless steel cover, 50 Hz motor.

Stew/Strip Cutter
Fajitas, chicken fingers, etc.

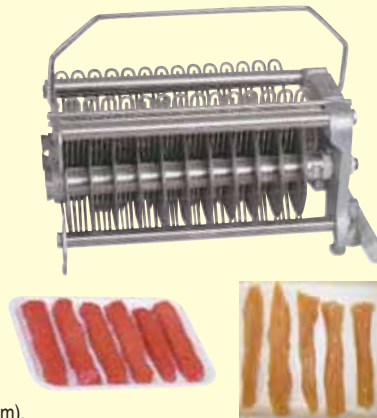

Create a value-added cube steak by moving the rear stripper (comb) to the most rear slot position. Pass 2-3 smaller pieces of hard to merchandize meat thru 2-3 times which knits the pieces together.

manual feed grinders

MODEL 722 MEAT GRINDER

Finish: Cast aluminum body, tinned bowl, ring, and worm.

Motors: 1 HP (.75kw), 115/230V, 60 Hz, 1 or 3 phase totally enclosed standard, 50 Hz available.

Switch: Toggle

Feed Pan: Stainless steel standard 20" (508mm) L x 13" (330mm) W x 2-1/2" (64mm) D.

Transmission: High torque drive, 95% efficient.

Bowl Type: Size 22 straight side.

Capacity: 10 - 16 lbs. (4.5-7.3kg) per minute.

Standard Equipment: Meat stomper, 6' cord and plug, 115 volt.

Options: Size 22 plate and knife.
(Extra Cost)



MODEL 812SS/822SS (shown) MEAT GRINDER

Finish: High polish stainless steel case, tinned bowl, ring, and worm.

Motors: 1 HP (.75kw), 115/230V, 60 Hz 1 or 3 phase open standard; 50 Hz available.

Switch: Toggle activator with magnetic contactor.

Feed Pan: Stainless steel standard, 20" (508mm) L x 13" (330mm) W x 2-1/2" (64mm) D.

Transmission: High torque drive, 95% efficient.

Bowl Type: Size 12 (Model 812) size 22 (Model 822), straight side.

Capacity: 812 6-10 lbs. (2.7-4.5kg) per minute.
822 10-16 lbs. (4.5-7.3kg) per minute.

Standard Equipment: Meat stomper, 6' cord and plug, 115 volt.

Options: 812 - size 12 plate and knife.
822 - size 22 plate and knife.
(Extra Cost)



MODEL 922SS MEAT GRINDER

Finish: High polish stainless steel case, tinned bowl, ring, and worm.

Motors: 1 HP (.75kw), 115/230V, 60 Hz, 1 or 3 phase standard. 50 Hz available.

Switch: Magnetic contactor with front mounted push button station and tray safety interlock.

Feed Pan: Stainless steel standard, removable, 26-3/4" (679mm) L x 15-1/2" (394mm) W x 2-3/4" (70mm) D.

Transmission: High torque drive, 95% efficient.

Bowl Type: Size 22, flared.

Capacity: 12-20 lbs. (5.4-9.1kg) per minute.

Standard Equipment: Bowl guard, meat stomper, 6' cord and plug, 115 volt.

Options: Size 22 plate and knife.
(Extra Cost)



MODEL 6642 MEAT GRINDER

Finish: High polish stainless steel case, tinned bowl, ring, and worm.

Motors: 2 HP (1.5kw), 115/230V, 60 Hz, 1 or 3 phase standard; 50 Hz available.

Switch: Waterproof push button with magnetic contactor.

Feed Pan: Stainless steel standard, removable, 39" (991mm) L x 20" (508mm) W x 4-3/4" (121mm) D.

Transmission: Double reduction steel gear type, oil bath.

Bowl Type: Size 42, flared, uses size 32 knife and plate.

Capacity: Up to 41 lbs. (19kg) per minute.

Legs: 4" (102mm) standard, 22" (559mm) available at extra cost.

Standard Equipment: Spurt guard, bowl guard, meat stomper, ring wrench.

Options: Size 32 plate and knife, longer legs.
(Extra Cost) Power cord, plug.



MODEL 346SS MEAT GRINDER

Finish: Stainless steel case, tray and guard, tinned bowl, ring, and worm.

Motors: 3 HP (2.25kw), various voltages, 50/60 Hz, 1 phase or 3 phase.

Switch: Magnetic type with thermal overload and under voltage protection.

Feed Pan: Left hand feed, removable, 45" (1143mm) L x 24" (611mm) W x 7-1/4" (184mm) D.

Transmission: Heavy duty roller chain drive.

Bowl Type: Size 46, straight chute type, uses size 32 knife and plate.

Capacity: 25 - 40 lbs. (11-18kg)/minute.

Standard Equipment: Spurt guard, bowl guard, ring wrench, meat stomper.

Options: Size 32 plate and knife, SS bowl, ring, and worm, leg extensions, right hand feed.
(Extra Cost)



MODELS 548SS, 7548SS, 552SS, 7552SS HHP MEAT GRINDERS

Finish: Stainless steel case, tray, and guard, tinned bowl, ring, and worm.

Motors: 5 (3.7kw), or 7-1/2 (5.6kw) HP, various voltages, 50/60Hz, 1 phase (5 HP only) or 3 phase.

Switch: Magnetic type with thermal overload and under voltage protection.

Feed Pan: Left hand feed, removable, 52" (1321mm) L x 29" (737mm) W x 9" (229mm) D.

Transmission: Heavy duty roller chain drive.

Bowl Type: Size 48 or 52 flared, uses size 32 or 52 knife and plate.

Capacity: 25 - 100 lbs. (11-45kg)/minute.

Standard Equipment: Spurt guard, bowl guard, ring wrench, meat stomper.

Options: Plate and knife, 550 volt motor, leg extensions, right hand feed, 5 HP (3.7kw), 1 phase motor.
(Extra Cost)



manual feed grinders

MODELS 1056SS, 1556SS HHP MEAT GRINDERS

- Finish: Stainless steel case, tray, and guard, tinned bowl, ring, and worm.
- Motors: 10 (7.5kw) or 15 (11.2kw) HP, various voltages, 50/60Hz, 3 phase.
- Switch: Magnetic type with thermal overload and under voltage protection.
- Feed Pan: Left hand feed, removable, 52" (1321mm) L x 29" (737mm) W x 9" (229mm) D.
- Transmission: Heavy duty roller chain drive.
- Bowl Type: Size 56 flared, uses size 56 knife and plate.
- Capacity: Up to 125 lbs. (56.7kg)/minute.
- Standard Equipment: Spurt guard, bowl guard, ring wrench, meat stomper.
- Options (Extra Cost): Plate and knife, 550 volt motor, leg extensions, right hand feed.



TANDEM SYSTEM

Model HHP to AFMG-48 Tandem System

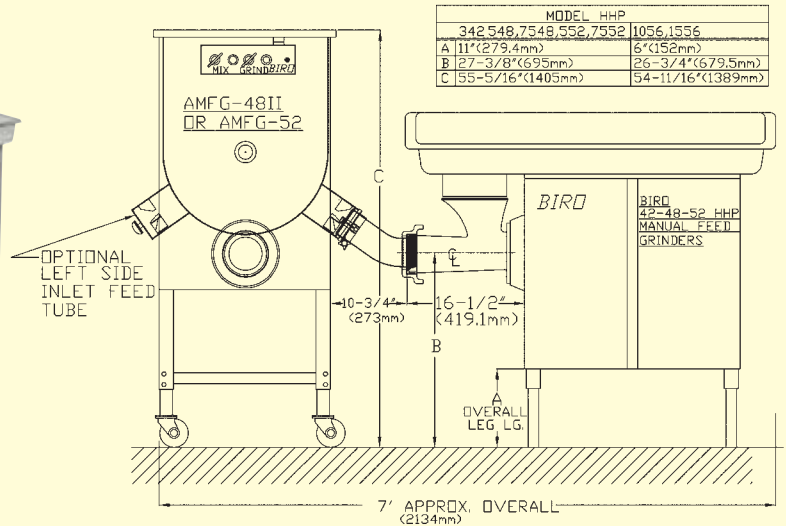

tempered frozen block chipper

MODEL FBC-4800SS CHIPPER

- Finish: Stainless steel construction.
- Motors: 5 HP (3.7kw), 208/220, 440-60-3, 575-60-3, 220/380-415-50-3.
- Switch: Magnetic type with low voltage and overload protection.
- Transmission: Oil bath with heavy duty bronze gear fitted directly to motor.
- Standard Equipment: Polyethylene product receptacle, product receptacle dolly, floor bolt down locator chocks, operating and safety manual.
- Operation: Maximum block size 8" (203mm) x 16-1/2" (419mm) x 19-1/2" (495mm), recommended block temperature is 15° to 25° F or -10° to -4° C, can reduce block into chips approximate 3-1/2" (89mm) x 3-1/2" (89mm) x 1/4" (6mm) in less than 60 seconds.
- Cleaning: Entire lid opens for easy access, knife shuttle assembly removable as a unit for cleaning.
- Options (Extra Cost): Stainless steel discharge chute, power cord (specify length).



poultry cutter

MODEL BCC-100 POULTRY CUTTER

- Finish: Stainless steel, cast aluminum.
- Motor: 3/4 HP (.56kw), 1 phase, totally enclosed; 3 phase and 50 Hz motors available at extra cost.
- Switch: Enclosed, water proof tilt type with red (ON) safety light.
- Knife Blade: 9" (229mm) diameter, stainless steel knife type blade.
- Standard Equipment: 5' cord and plug, 115 volt.
- Options (Extra Cost): 9" (229mm) diameter, stainless steel serrated blade.



vacuum marinaters



MODELS VTS-41 AND VTS-42 VACUUM (shown) MARINATING TUMBLERS

Finish: Stainless steel frame, except wheels and lid gasket.
 Drum Motor: 1/25 HP (.03kw), 115V, 60 Hz, 1 phase.
 Vacuum Pump: 1/8 HP (.09kw), 115V, 60 Hz, 1 phase. Portable pump (VTS-41). Enclosed pump (VTS-42).
 Capacity: 40 lb. (18kg) capacity stainless steel drum.
 Standard Features: Tumbling timer, 6' cord and plug, removable baffles as illustrated.
 Options: 50 Hz motor for 42, variable speed (0-8 RPM), tumbler cart. (Extra Cost)



MODEL VTS-43 (shown) AND VTS-44 VACUUM MARINATING TUMBLERS

Finish: Stainless steel frame, except wheels and lid gasket.
 Drum Motor: 1/25 HP (.03kw), 115V, 60 Hz, 1 phase.
 Vacuum Pump: 1/8 HP (.09kw), 115V, 60 Hz, 1 phase. Portable pump (VTS-43). Enclosed pump (VTS-44).
 Capacity: Twin 20 lb. (9.1kg) capacity stainless steel drums.
 Standard Features: Tumbling timer, 6' cord and plug.
 Options: 50 Hz motor for 44, variable speed (0-8 RPM), 40 lb. (18kg) stainless steel drum, -----tumbler cart. (Extra Cost)

REMOTE VACUUM PUMP For Models VTS-41/43/45.



MODEL VTS-45 AND VTS-46 (shown) VACUUM MARINATING TUMBLERS

Finish: Stainless steel except the wheels & lid gaskets.
 Drum Motor: 1/25 HP (.03kw).
 Vacuum Pump: 1/8 HP (.09kw) portable pump with filter VTS-45. 1/8 HP (.09kw) internal pump with external filter on case VTS-46.
 Capacity: 20 pound (9.1kg) drum, maximum, 15 lbs (7 KG) optimum.
 Standard Features: 6' cord, 3 prong plug, 115-60-1. 6' cord, no plug, 220-6-1 and 220-50-1, removable baffles as illustrated. Operating and safety manual.
 Options: Variable speed (0-8 RPM), tumbler cart, wood box. (Extra Cost)

MODELS VTS-41, 42, 43, 44, 45, or 46 TABLE TOP VACUUM TUMBLERS CAN BE BOLTED TO THE FRAME OF THE OPTIONAL TUMBLER CART BELOW.



VT63077C OPTIONAL TUMBLER CART

Stainless steel with bottom shelf and 4 locking swivel casters.

OPTIONAL CONTROL PANEL COVER

Water protected. (VTS-100 / VTS-500)



MODEL VTS-100 VACUUM TUMBLER

Finish: Stainless steel frame, drum and case.
 Drum Motor: 3/4 HP (.56kw) Variable Speed, 115V, 60 Hz, 1 phase
 Vacuum Pump: 3/4 HP (.56kw), 115V, 60 Hz, 1 phase. External moisture trap.
 Drum Capacity: 100 lb. (45.4kg) approximate.
 Standard Features: 0-50 minute interval mode timer, in-line vacuum filter, lock swivel casters, 8' cord and plug 115 volts, photo eye for safety shutdown.
 Options: 50 cycle, reverse jog switch (momentary), extension legs, protective enclosure assembly. (Extra Cost)



MODEL VTS-500 VACUUM TUMBLER

Finish: Stainless steel frame, drum and case.
 Drum Motor: 3/4 HP (.56kw) Variable Speed, 115V, 60 Hz, 1 phase,
 Vacuum Pump: 3/4 HP (.56kw), 115V, 60 Hz, 1 phase. External moisture trap.
 Drum Capacity: 500 lb. (227kg) approximate.
 Standard Features: 0-99 minute timer with repeat cycle run-stop-run, external moisture trap, in-line vacuum filter, locking swivel casters, 8' cord and plug 115 volts, photo eye for safety shutdown.
 Options: 50 cycle, reverse jog switch (momentary), extension legs, protective enclosure assembly. (Extra Cost)

meat & food slicers

MODEL B300M GRAVITY FEED MANUAL SLICER

Finish: Body – Anodized polished aluminum cast with non-corrosive metal frame.
Motor: IP 65 – 1/2 HP (.35 KW) 115V 60 HZ 1 ph internally cooled, water resistant.
IP 65 – 1/2 HP (.35 KW) 220V 50 Hz 1 ph internally cooled, water resistant.
Blade Size: 12" (300 mm) hollow ground alloy steel.
Max. Slice Thickness: 5/8" (16 mm).
Max. Round Cut: 7.5" (191 mm).
Max. Rectangle Cut: 10" x 5.5" (254 mm x 140 mm).
Standard Features: Removable product table, blade protective ring guard, product table lockout, automatic spring loaded belt tensioning, polygroove belt drive, thermal overload/no volt release, green pushbutton on-off control with red e-stop button, water resistant IP65 motor, wiring harness, electronic controls, and connectors, detachable sharpener assembly, product fence, 6-1/2' cord, 3 prong plug, 115-60 volt.



Model B300M (detachable sharpener not shown)

MODEL B350M GRAVITY FEED MANUAL SLICER

Finish: Body – Anodized polished aluminum cast with non-corrosive metal frame.
Motor: IP 65 – 1/2 HP (.37 KW) 115V 60 HZ 1 ph internally cooled, water resistant.
IP 65 – 1/2 HP (.37 KW) 220V 50 Hz 1 ph internally cooled, water resistant.
Blade Size: 13-3/4" (350 mm) hollow ground alloy steel.
Max. Slice Thickness: 1-3/16" (30 mm).
Max. Round Cut: 10" (254 mm).
Max. Rectangle Cut: 12-1/2" x 9" (318 mm x 229 mm).
Standard Features: Oversized product table, blade protective ring guard, tilt-away product table lockout, automatic spring loaded belt tensioning, belt drive, thermal overload/no volt release, green pushbutton on-off control with red e-stop button, water resistant IP65 motor, wiring harness, electronic controls, and connectors, detachable sharpener assembly, product fence, 6-1/2' cord, 3 prong plug, 115-60 volt.



Model B350M (detachable sharpener not shown)

MODEL B350COMFORT SEMI-AUTOMATIC SLICER

Finish: Body – Anodized polished aluminum cast with non-corrosive metal frame.
Motor: IP 65 – 1/2 HP (.37 KW) 115V 60 HZ 1 ph internally cooled, water resistant.
IP 65 – 1/2 HP (.37 KW) 220V 50 Hz 1 ph internally cooled, water resistant.
Blade Size: 13-3/4" (350 mm) hollow ground alloy steel.
Max. Slice Thickness: 1" (25.4 mm).
Max. Round Cut: 9-1/4" (235 mm).
Max. Rectangle Cut: 11-3/4" x 6" (298 mm x 152 mm).
Standard Features: Oversized product table, blade protective ring guard, tilt-away product table lockout, automatic spring loaded belt tensioning, poly groove belt drive, thermal overload/no volt release, water resistant IP65 motor, wiring harness, electronic controls and connectors, detachable sharpener assembly, product fence, machine lift handle for ease of cleaning, single speed at 40 strokes/min.



Model B350COMFORT (detachable sharpener not shown)

MODEL B350A SEMI-AUTOMATIC SLICER

Finish: Body – Anodized aluminum polished cast with non-corrosive metal frame.
Motor: IP 65 – 1/2 HP (.37 KW) 115V 60 HZ 1 ph internally cooled, water resistant.
IP 65 – 1/2 HP (.37 KW) 220V 50 Hz 1 ph internally cooled, water resistant.
Blade Size: 13-3/4" (350 mm) hollow ground alloy steel.
Max. Slice Thickness: 1" (25.4 mm).
Max. Round Cut: 9-1/4" (235 mm).
Max. Rectangle Cut: 11-3/4" x 6" (298 mm x 152 mm).
Standard Features: Oversized product table, blade protective ring guard, tilt-away product table lockout, automatic spring loaded belt tensioning, polygroove belt drive, thermal overload/no volt release, water resistant IP65 motor, wiring harness, electronic controls, and connectors, detachable sharpener assembly, product fence, 6-1/2' cord, 3 prong plug, 115-60 volt. Three stroke lengths/ten stroke speeds.



Model B350A (detachable sharpener not shown)

horizontal slicer

TEMPERED / FRESH BONELESS WHOLE MEAT SLICER



Shown with conveyor.

MODEL 109PC HORIZONTAL SLICER (ELECTRONIC PROGRAM)

- Electrical: 3 HP (2.2kw), 208/220/440 volts, 60 Hz, 3 phase, 220/380/415 volts, 50 Hz, 3 phase, 10' cord no plug. Must specify exact voltage prior to ordering.
- Finish: Stainless steel frame and skin. Lexan chamber lids.
- Chamber Size: 9" (228 mm) high x 10" (254 mm) wide x 30" (762 mm).
- Safety: Magnetic interlocks on all doors, brake motor, locking casters, OSHA lockout power switch.
- Blades: Stainless steel curved sickle type. Two blades supplied with each machine, one smooth or serrated blade on the machine and whichever one you want extra.
- Blade Speed: Up to 180 cuts per minute.
- Controller: Electronic, splash proof, user friendly keypad in English or metric (tactile and audible), programmable up to 7 programs, automatic transport return.
- Cut Thickness: 1/16" plus (2.0 mm) minimum or 30" (762 mm) maximum.
- Standard: 5" Dia. total-lock swivel casters with prevenz, operating manual, 10' cord, size 12, 4 wire, no plug, 2 blades, surplus catch tray, product leaf spring.
- Options: Serrated blade, 10" W x 48-3/8" L take away conveyor variable speed from 0-55 ft. (Extra Cost) (0-5.1m) per minute, independent on-off switch, white food grade removable belt, all doors have safety interlocks.



Model 109PC/109PCM
Sickle type
smooth edge blade.

MODEL 109PCM HORIZONTAL SLICER (WITH MECHANICAL THICKNESS ADJUSTMENT)

- Electrical: 2 HP (1.5kw), 208/220/440 volts, 60 Hz, 3 phase, 220/380/415 volts, 50 Hz, 3 phase, 10' cord no plug. Specify voltage prior to ordering.
- Finish: Stainless steel frame and skin. Lexan chamber lids.
- Chamber Size: 9" (228 mm) high x 10" (254 mm) wide x 30" (762 mm).
- Safety: Magnetic interlocks on all doors, brake motor, locking casters, OSHA lockout power switch.
- Blades: Stainless steel curved sickle type. Two blades supplied with each machine, one smooth or serrated blade on the machine and whichever one you want extra.
- Blade Speed: Up to 170 cuts per minute.
- Controller: Main on off, run or jog, push button start, emergency "E" stop.
- Cut Thickness: 1/16" plus (2.0 mm) minimum or 1-1/8" (28.6 mm).
- Standard: 5" Dia. total-lock swivel casters with prevenz, operating manual, 15' cord, size 12, 4 wire, no plug, 2 blades, surplus catch tray, product leaf spring.
- Options: Serrated blade, 10" W x 48-3/8" L take away conveyor variable speed from 0-55 ft. (0-5.1m) per minute, independent on-off switch, white food grade removable belt, all doors have safety interlocks.



Thickness adjuster right side.



Enlarged

food / patty formers



Shown with Optional Feed Tray. Feed Tray not available on EH's.

MODEL F2000N

Finish: Anodized polished aluminum body with stainless steel enclosures.
 Motor: 3/4HP (.56kw), 115V 60 Hz 1ph.
 Production: 2000 Single shapes per hour.
 Shape Size: 1" to 4-3/4" / 25.4mm to 121mm.
 Hopper Size: 6.5 gallons / 25 lt.

MODEL F3000N

Finish: Anodized polished aluminum body with stainless steel enclosures.
 Motor: 3/4HP (.56kw), 115V 60 Hz 1ph.
 Production: 3000 Single shapes per hour.
 Shape Size: 1" to 4-3/4" / 25.4mm to 121mm.
 Hopper Size: 6.5 gallons / 25 lt.

MODEL F4000N

Finish: Anodized polished aluminum body with stainless steel enclosures.
 Motor: 1HP (.75kw), 115V 60 Hz 1ph.
 Production: 4000 Single shapes per hour.
 Shape Size: 1" to 4-3/4" / 25.4mm to 121mm.
 Hopper Size: 6.5 gallons / 25 lt.

Standard Equipment: manual wire drum cleaner, paper holder, pneumatic foot switch, 6.5 gal. (25 lt.) product hopper, 15-3/8 (390.5mm) (NSF) conveyor belt, 2 packs (1330 sheets) single ply patty paper, one standard single round hole mold poly drum, lifting handle for cleaning.

Options (Extra Cost) – larger hopper, automatic wire drum cleaner, longer conveyor belt, stainless steel feed tray except on EH models.



Paper Holder standard on machine



Standard Single Round Hole Mold Poly Drum (no charge), Select One

70mm, 2.75" diameter	110mm, 4.33" diameter
90mm, 3.50" diameter	115mm, 4.50" diameter
100mm, 3.93" diameter	120mm, 4.72" diameter
	127mm, 5.00" diameter

Manual drum wire cleaner is standard.
 Automatic drum wire cleaner (optional, extra cost, not shown)

NOTE: ALL OTHER DRUMS SUCH AS SHOWN BELOW ARE OPTIONAL, EXTRA CHARGE.



Single Round
Optional Sizes



Single Oval



Double Rectangle



Single Square



Rectangle



Round Double

Call your Sales Representative or the factory for other shapes and sizes not listed above.

MODEL HD3000EHN PNEUMATIC

Finish: Anodized polished aluminum body with stainless steel enclosures.
 Motor: 3/4HP (.56kw), 115V 60 Hz 1ph.
 Production: 3000 Single shapes per hour.
 Shape Size: 1" to 4-3/4" / 25.4mm to 121mm.
 Hopper Size: 10.5 gal (45 lt) product hopper
 Std. Features: Take-away conveyor w/built in Machine Stand.
 Built-in Pneumatic wire drum scraper, foot switch,
 longer conveyor belt 45" (1180mm), 2 rolls patty paper 1330 sheets.





COMPANY PROFILE STATEMENT

The **BIRO® MANUFACTURING COMPANY** established in 1921, is an Ohio, USA corporation, with three manufacturing/assembly plants. BIRO designs, manufactures, and markets safe, durable, and reliable power operated, stainless steel, food and meat processing machinery. BIRO is committed to satisfy specific needs of all segments of the food and meat industry: the food retail stores, the food service, and the food processing, including portion control and the seafood processing operations.

BIRO's product line includes a broad selection of models and variations of Power Saws, Tenderizers/Knitters, Cubers, Strip Cutters, Poultry Cutters, Horizontal High Speed Meat Slicers, Deli/Meat Slicers, Grinders, Mixer/Grinders, Marinating Vacuum Meat Tumblers, and Food/Patty Formers.

BIRO PHILOSOPHY

- ▶ **BIRO ENGINEERING & DESIGN:** Our concept is for optimum performance and efficiency with safety and sanitation as our priority in the design process. We specialize in being able to modify our machines to meet your requirements.
- ▶ **BIRO MACHINES:** Our concept of a "better buy" for the customer is not only based on initial acquisition cost but more importantly... machines built to last longer. There's increased productivity throughout the machine's life because of less down time.
- ▶ **BIRO PARTS:** The customer will realize lower maintenance costs with reasonably priced parts, less frequent replacement requirements, thus less labor needed. The quality of BIRO parts in relation to cost is the most competitive in the industry.
- ▶ **BIRO TECHNICAL SERVICE:** The end users will benefit from highly motivated, independently owned, authorized sales and service distributors worldwide. These distributors have the benefit of factory training and technical staff support.
- ▶ **BIRO CUSTOMER SERVICE:** With the cooperation of all our employees, we will continue to strive to build long standing relationships with our valued customers by providing responsive customer service.

Service is available from locations worldwide

Since 1921, **BIRO®** Manufacturing Company has developed and manufactured safe and reliable food processing equipment to meet the various requirements of the food processing industry. **BIRO** also designs and builds special food processing machines according to customer specifications. A wide variety of models are available from which to select as well as a number of electrical motor and controller options. It is important that electrical specifications for your particular application be specified when inquiring. If additional assistance is needed regardless whether the equipment is standard or special, contact your authorized distributor covering your locality or the Sales Department of the **BIRO** Manufacturing Company, Marblehead, Ohio 43440 U.S.A.

BIRO® is the registered trademark of Biro Manufacturing Company, Marblehead, Ohio 43440 as applied to power driven meat, fish, and bone cutting machines, meat grinders, tenderizers, chippers, slicers and cutters; automatic feed mixer-grinders, vacuum tumblers, patty/food formers, blades and parts thereof of its manufacture or design for use in the food processing industry.

THE INFORMATION AND FINDINGS CONTAINED HEREIN REPRESENT OUR BEST JUDGEMENT BASED ON WORK DONE AND TESTS PERFORMED. THE BIRO MANUFACTURING COMPANY ASSUMES NO LIABILITY WHATSOEVER EXPRESSED OR IMPLIED IN CONNECTION WITH ITS USE. AS GOVERNMENTAL REGULATIONS AND CONDITIONS MAY CHANGE, IT IS THE BUYER'S RESPONSIBILITY TO DETERMINE THE APPROPRIATENESS OF SELLER'S PRODUCT FOR BUYER'S SPECIFIC END USE. ALL SPECIFICATIONS CONTAINED HEREIN ARE SUBJECT TO CHANGE WITHOUT NOTIFICATION.

Food Processing Machine Manufacturers

BIRO MANUFACTURING COMPANY, 1114 W. MAIN ST., MARBLEHEAD, OHIO 43440-2099 U.S.A.

Phone:+1 (419) 798-4451 FAX:+1 (419) 798-9106 <http://www.birosaw.com> email: sales@birosaw.com

Item No: Lit-Stuffer-300

Form No: Stuffer-300-3-15-23-MARK